

ASSEMBLY INSTRUCTIONS for PENT SHED 6x4

E0019



**PLEASE READ ASSEMBLY
INSTRUCTIONS COMPLETELY
BEFORE ASSEMBLING YOUR
BUILDING**



CAUTION: Some parts have sharp edges. Care must be taken when handling the various pieces to avoid a mishap. For safety sake, please read the safety information provided in this manual before beginning construction. Wear gloves when handling metal parts.

IMPORTANT INFORMATION

PLEASE TAKE THE TIME TO READ THESE INSTRUCTIONS CAREFULLY BEFORE PROCEEDING WITH ANY ATTEMPT TO CONSTRUCT YOUR BUILDING. IDENTIFY AND CHECK ALL PARTS TO ENSURE THAT THERE ARE NO SHORTAGES, AS LEAVING A PARTLY FINISHED BUILDING IN ADVERSE WEATHER CONDITIONS CAN BE DANGEROUS AND DAMAGING TO THE BUILDING'S STRUCTURE.

PROCEED WITH CONFIDENCE, BUT PLEASE REFER TO THE MANUAL FOR METHOD OF CONSTRUCTION AS THIS WILL SIMPLIFY THE TASK FOR YOU. DO NOT BUILD YOUR BUILDING ON A WINDY DAY AS THIS COULD BE DANGEROUS!

BEFORE BEGINNING CONSTRUCTION, CHECK LOCAL BUILDING CODES.

TOOLS REQUIRED: No.2 PHILLIPS SCREWDRIVER (Magnetic Tip), PLIERS, CORDLESS DRILL, CARPENTERS LEVEL, SQUARE, LADDER, WORK GLOVES AND SAFETY GOGGLES

PERSONAL SAFETY DURING BUILDING CONSTRUCTION

Some of the building components may contain sharp edges prior to assembly. Wear protective work gloves and long sleeves while handling these components. Wear eye protection when using any form of power tool. Do not use household voltage power tools in a wet or damp environment. Do not use any part of the building's frame as a means of personal support while attaching components during assembly.

PREPARATION OF BUILDING SITE

This building must be constructed on a SOLID BASE FOUNDATION. We recommend a poured concrete pad or large size concrete patio stone squares for a suitable floor and base. Whichever you select.....*make sure your foundation area is firm and level and will allow drainage away from the site.* Make your solid base foundation 4" larger than your building.

The manufacturer is not responsible for the choice and the construction of the foundation.

NOTE: For a concrete pad base, prepare a level bed for a firm footing layer of crushed stone. Place a damp proof membrane over the crushed stone to help prevent dampness from rising up out of the ground. The concrete pad should then be poured to a thickness of 4" (100mm) to 5" (125mm). Taper the outer perimeter of the concrete pad downward from the building's base rails to allow drainage away from the building. When completed, allow to dry thoroughly for at least 48 hours.

YOUR BUILDING MUST BE ANCHORED

Your building must be firmly anchored to your concrete pad or large concrete patio stone squares ...to help protect against damage in high winds.

PARTS LIST

E0003

ITEMS LOCATED IN HARDWARE KIT



DOOR GLIDE



ROOF CORNER CAP



DOOR SPACER

ITEMS LOCATED IN INSTRUCTION MANUAL KIT



DOOR HANDLE



PLASTIC WASHER TREE



ADHESIVE PADS

PARTS LIST

E0020

Part Number	Part Description	Quantity
		6x4
64H	Rear Base Rail	2
62H	Front Base Rail	2
610H	Entry/Exit Ramp	1
640H	Rear Top Rail and Rear Midwall Brace	4
66H	Door Track	2
635H	Door Fascia	1
73H	Side Base Rail	2
5H__	Corner Panel	2
645H__	Half Corner Panel	2
442P	Left Gable	1
443P	Right Gable	1
A67	Door Glide	4
69H	Door Jamb	2
628H	Front Midwall Brace	2
687L	Front Fascia	2
SP8	Splice Plate	1
340H	Roof Brace	2
846H__	Half Wall Panel	2
21H__	Wall Panel	3
727M	Side Midwall Brace	2
A419P	Outer Roof Panel	2
B419P	Center Roof Panel	1
641P	Roof Edge Trim	4
841P	Roof Edge Trim	2
60H	Roof Corner Cap	4
622H__	Door Panel	2
DIS01	Door Strengthenener	4
80	Adhesive Pad	4
632	Top and Bottom Door Brace	4
48	Door Spacer	2
DH10	Door Handle	2
P61	Plastic Washer Tree	1
	Instruction Manual Kit	1
	Hardware Kit	1

1 Rear Base Rail – 64H (x2)

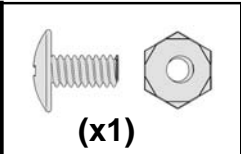

Overlap the rear base rails (2 pcs.) and align the large holes. Secure with a bolt and nut.

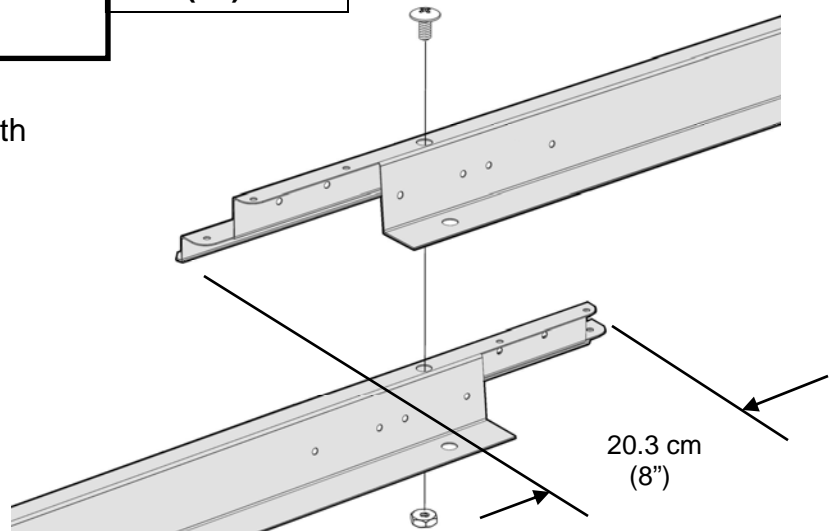

2 Front Base Rail – 62H (x2)
Entry/Exit Ramp – 610H (x1)

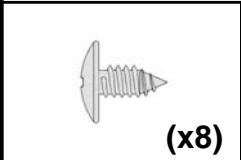

Splice the front base rails with the entry/exit ramp using 4 self tapping screws in each end of the ramp.

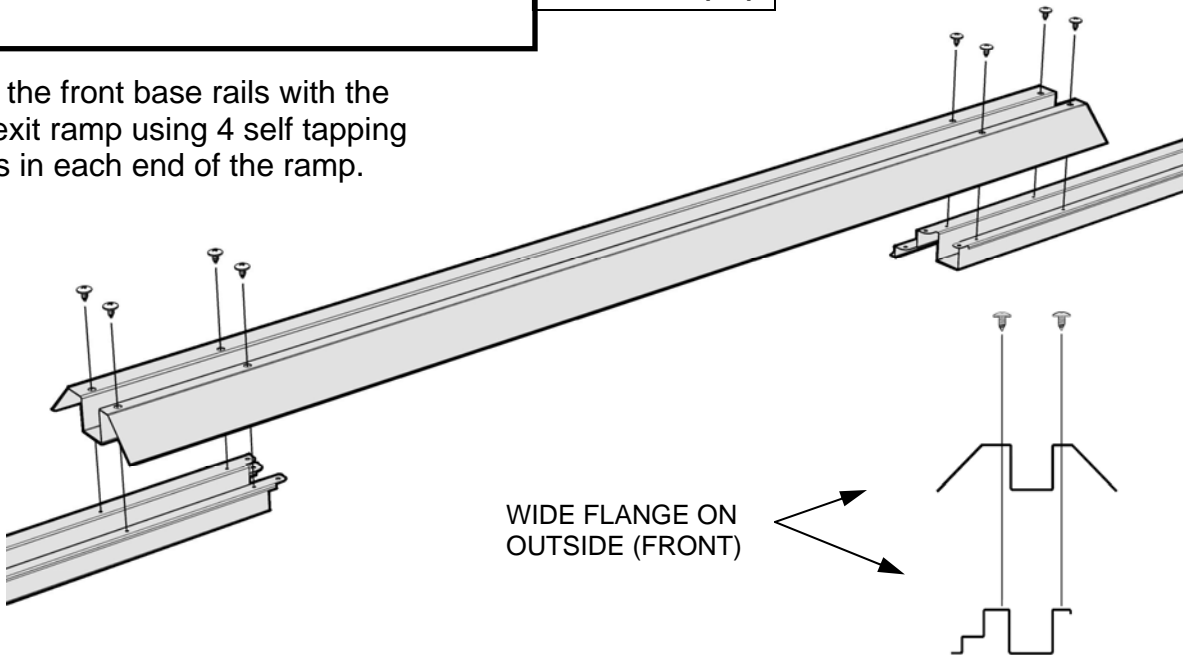

3

Rear Top Rail and
Rear Midwall Brace – 640H (x4)

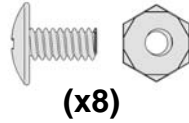

Overlap the rear top rails (2 pcs.) and align the large holes. Secure with bolts and nuts.

Repeat for rear midwall brace.

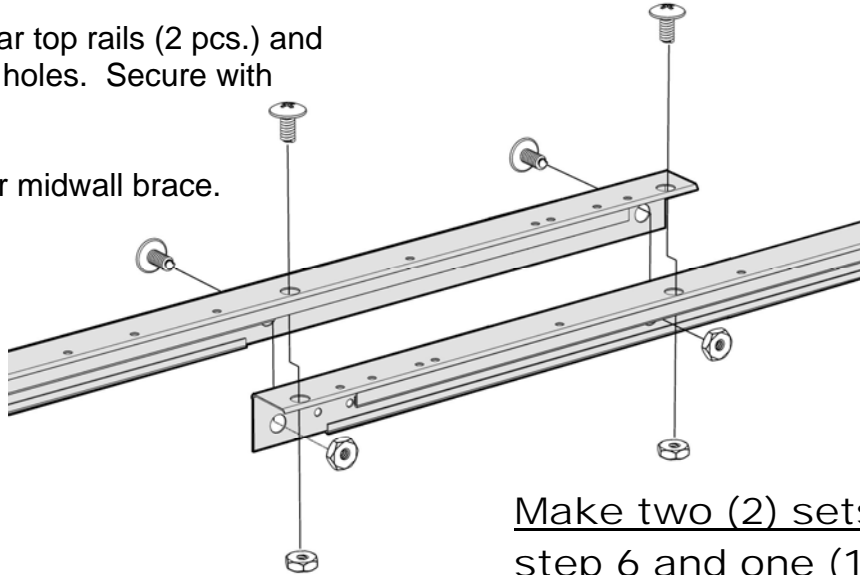

Make two (2) sets; one (1) for step 6 and one (1) for step 11

4

Door Track – 66H (x2)
Door Fascia – 635H (x1)



(x4)

Assemble the door track and door fascia together using self tapping screws from the inside (back) only.

NOTE: The side of door track with the most holes should face outside (front).

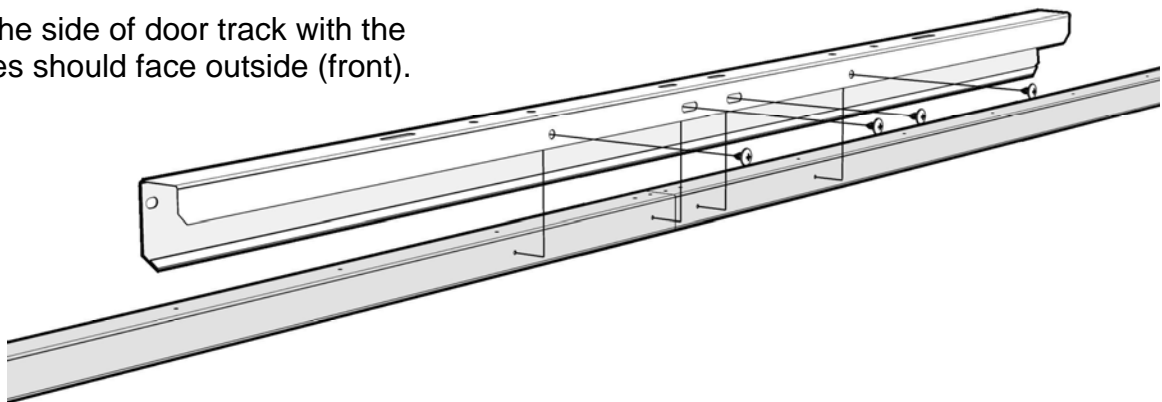

5 Side Base Rail – 73H (x2)
Base Rail Bracket – BR1 (x2)
(Located in Screw Covers Kit bag)
Assembled Rear and Front
Base Rails

Assemble all 4 base rails by securing at the outer corners using self tapping screws. Fasten base rail brackets to rear corners.



Check base frame for squareness by measuring diagonal corners. Your measurements should be equal.

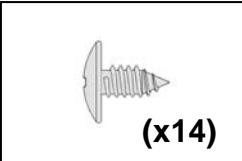
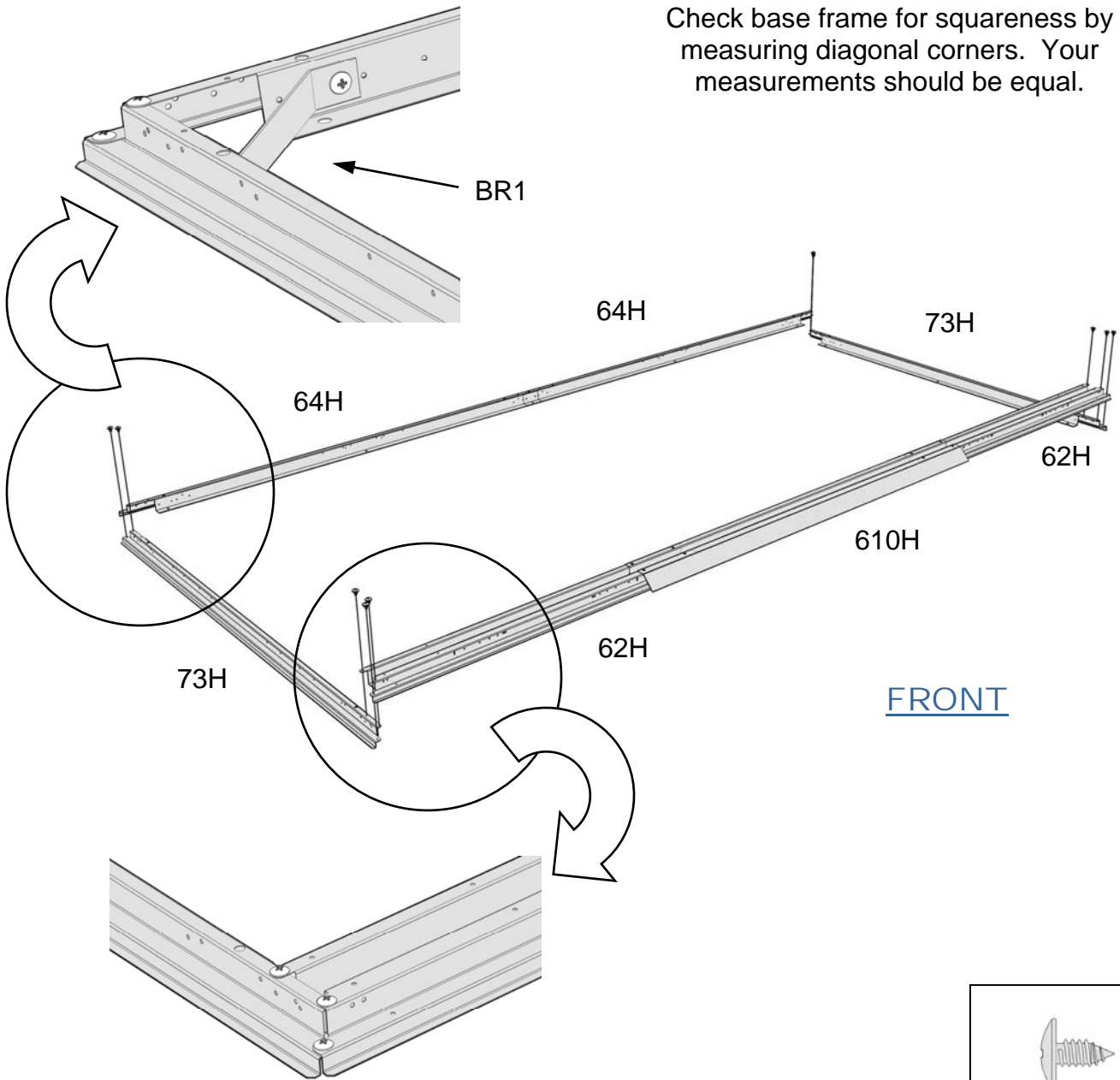

- 6** Corner Panel – 5H__ (x2)
 Half Corner Panel – 645H__ (x2)
 Left Gable – 442P (x1)
 Right Gable – 443P (x1)
 Door Glide – A67 (x4)
 Assembled Rear Top Rail and Door Track/Fascia

IMPORTANT: The narrow flange of the corner panel must be along the side of the building.

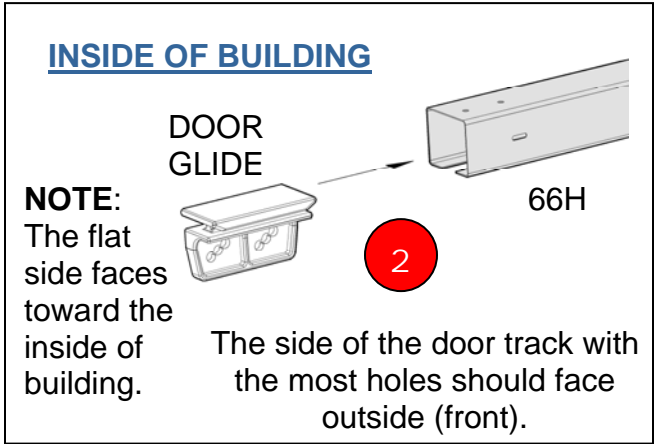

- 1** Position corner panels and fasten to base rails using self tapping screws.
- 2** Slide door glides into door track. Make sure they face the right way.
- 3** Fit gables, rear top rail and door track with door glides installed. Fasten to top of corner panels using self tapping screws.

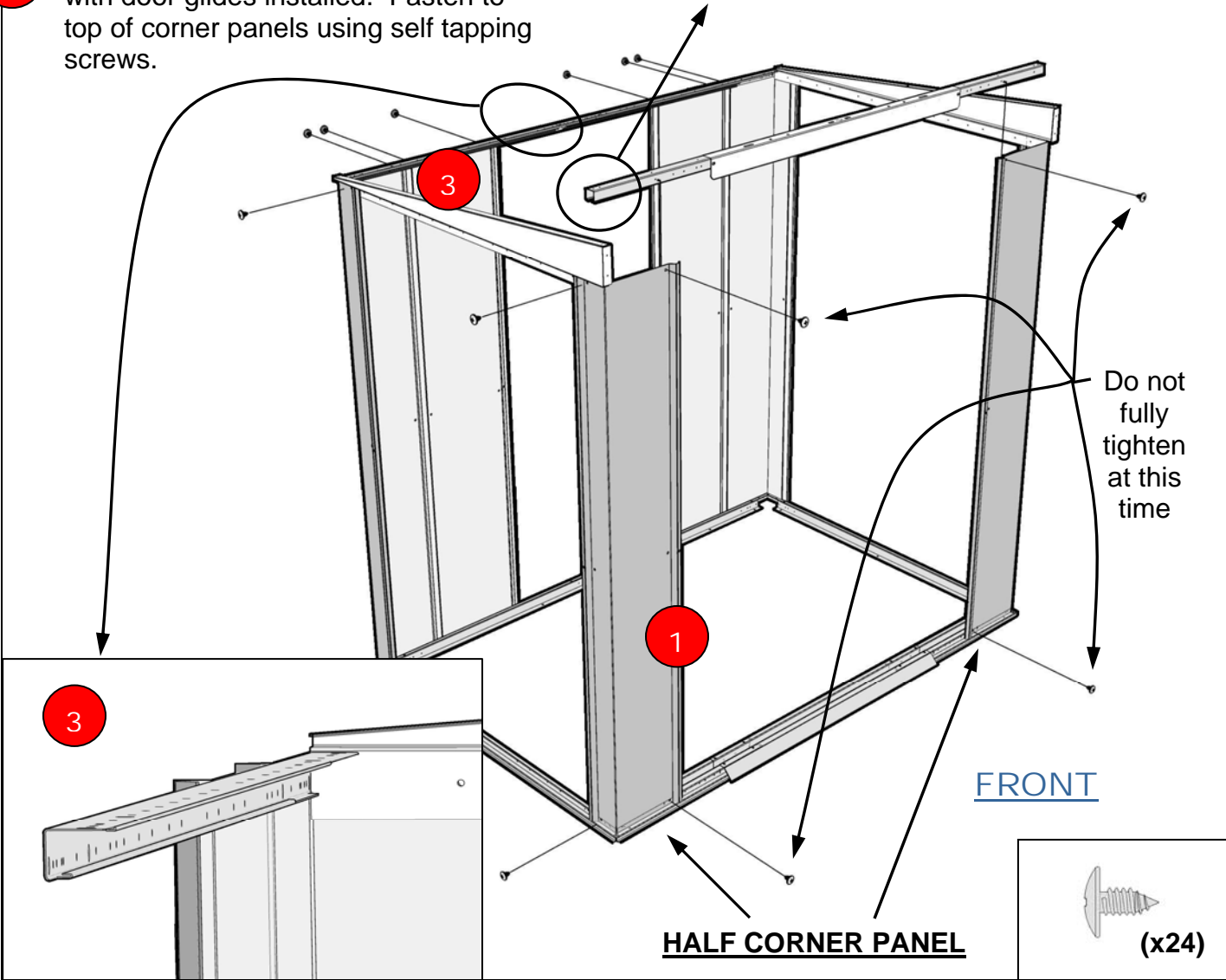

7

Door Jamb – 69H (x2)
Front Midwall Brace – 628H (x2)

1 Remove half corner panel screws as necessary and slide the door jamb under corner panel and door fascia. Fasten at base rail, and then fasten through the door fascia and door jamb into the side of door track using self tapping screws. Replace half corner panel screws.

2 Fasten door jamb to corner panels at midwall height using 10mm (3/8") bolts and nuts.

3 Install front midwall brace on each side of door.

IMPORTANT: Use 6mm (1/4") bolts and nuts.

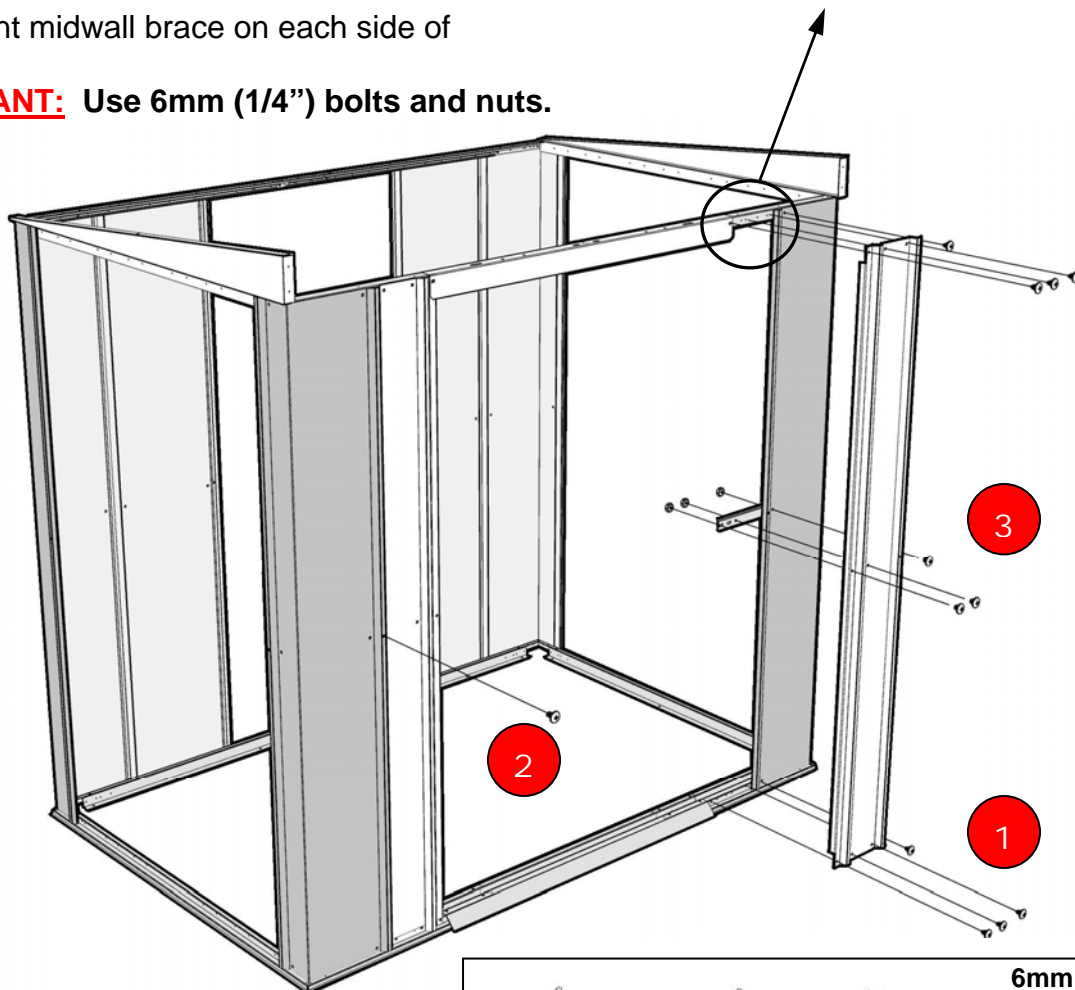
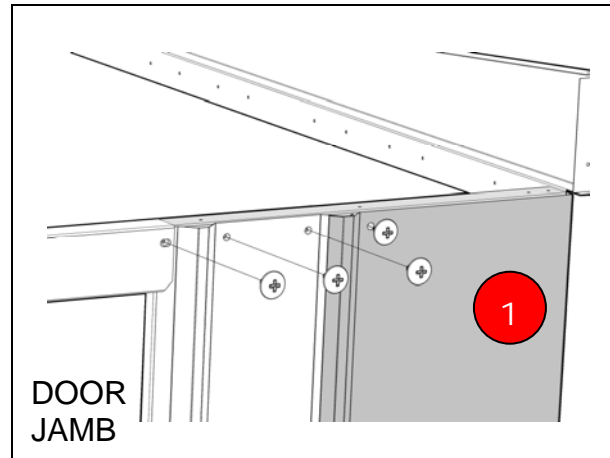

(x12)

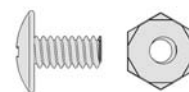

(x2)

6mm (1/4")

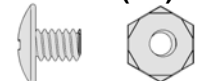

(x6)

8 Front Fascia – 687L (x2)
Splice Plate – SP8 (x1)

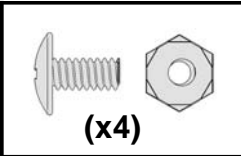

Splice the front fascia with the splice plate using 4 bolts and nuts.

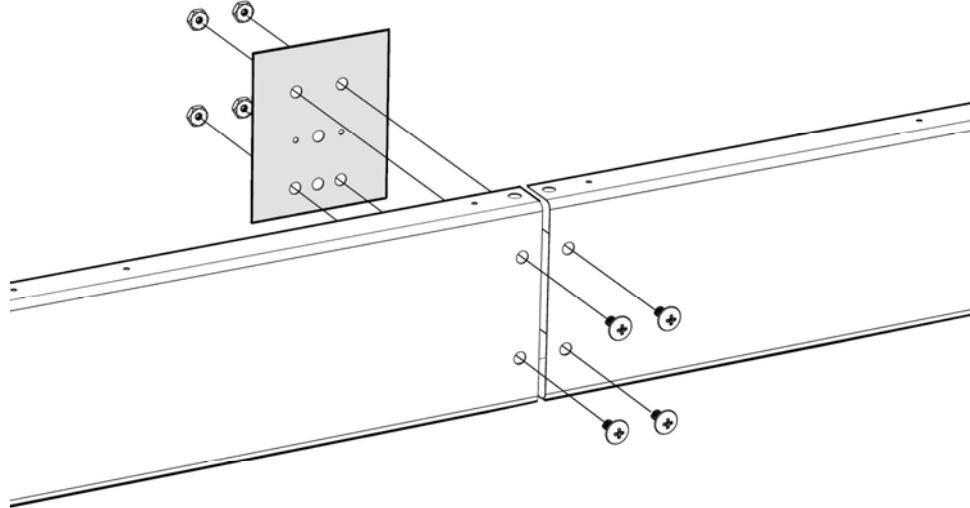

9 Roof Brace – 340H (x2)

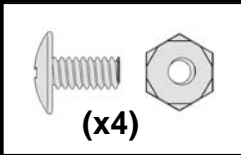

Overlap the roof braces (2 pcs.) and align the large holes. Secure with bolts and nuts.

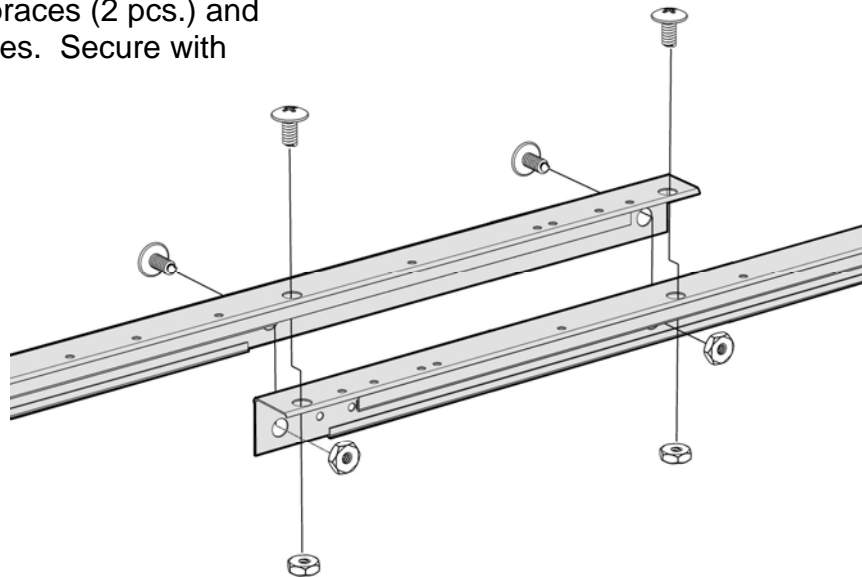

10 Half Wall Panel – 846H__ (x2)
 Wall Panel – 21H__ (x3)
 Assembled Front Fascia

1 Position wall panels and half wall panels as shown. Fasten at base rail and top rail using self tapping screws. Fasten rib overlap on all panels at midwall height using bolts and nuts.

2 Fasten front fascia to door track using self tapping screws. Secure to the front end of the gables with self tapping screws.

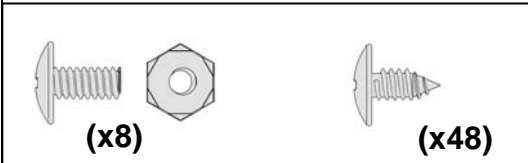
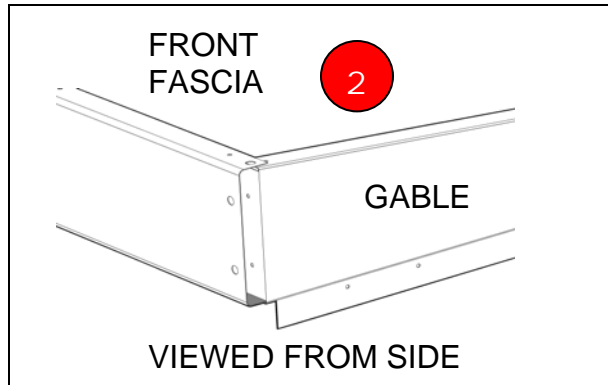
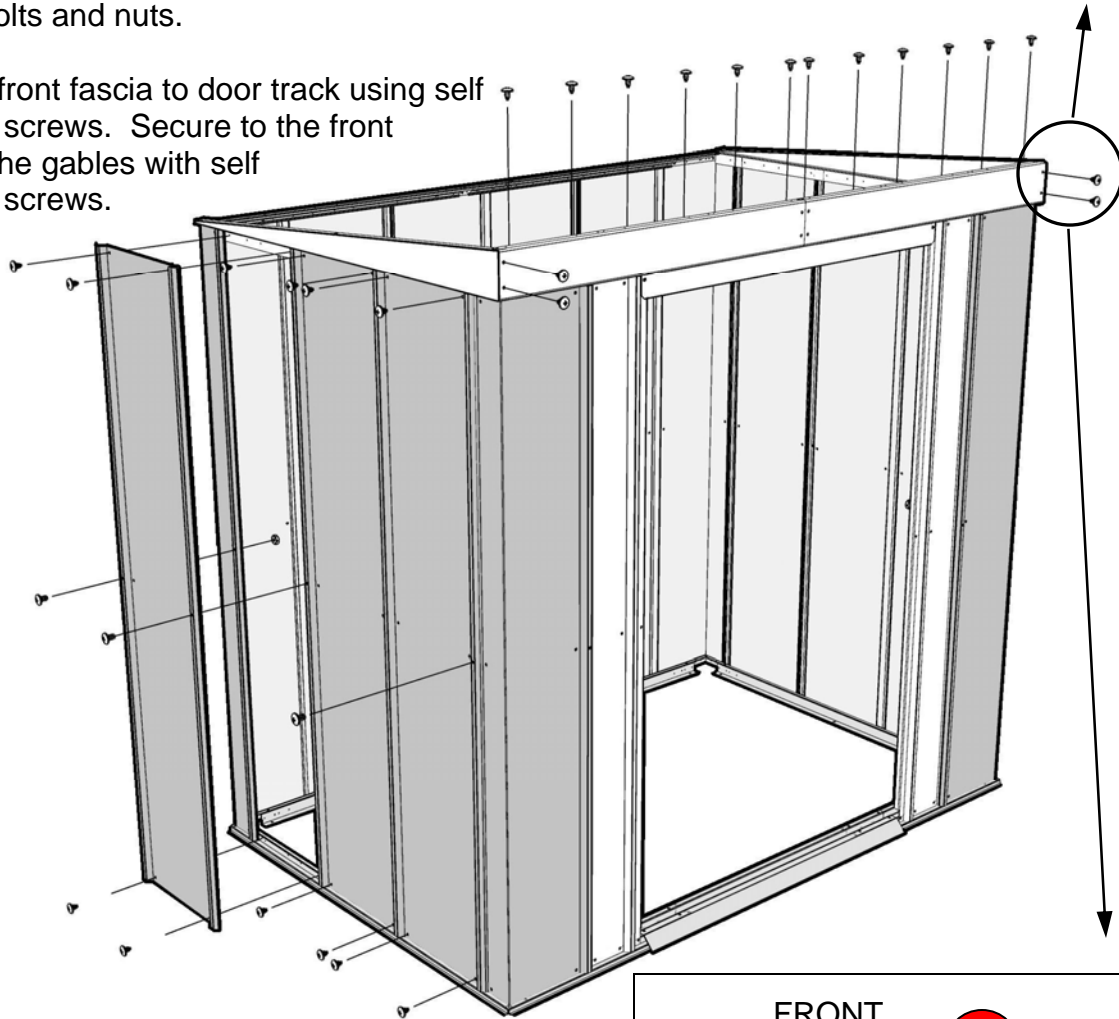
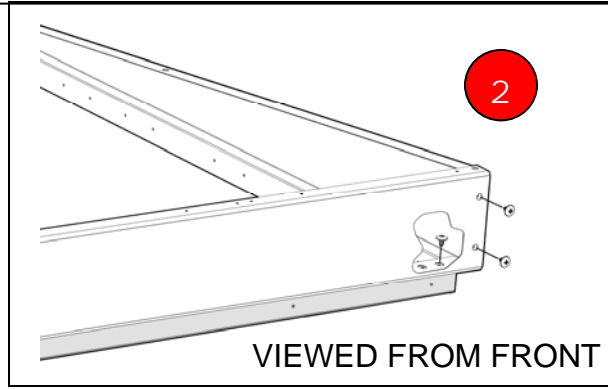

11 Side Midwall Brace – 727M (x2)
Assembled Rear Midwall Brace

- 1** Fasten side and rear midwall braces to corner panel and wall panels from the outside using self tapping screws.
- 2** Fasten the midwall braces together at the rear corners where they overlap using bolts and nuts.

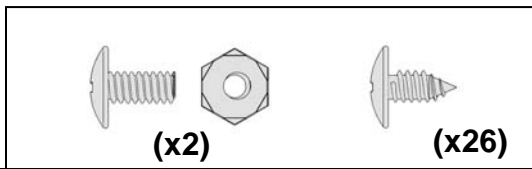
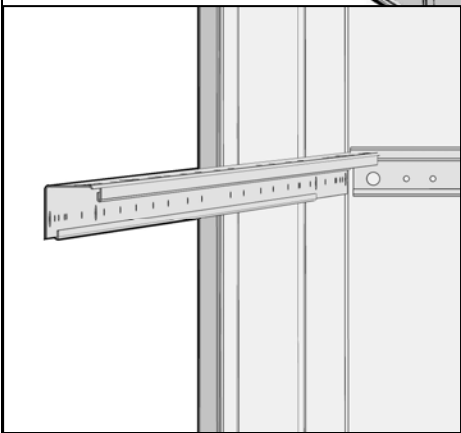
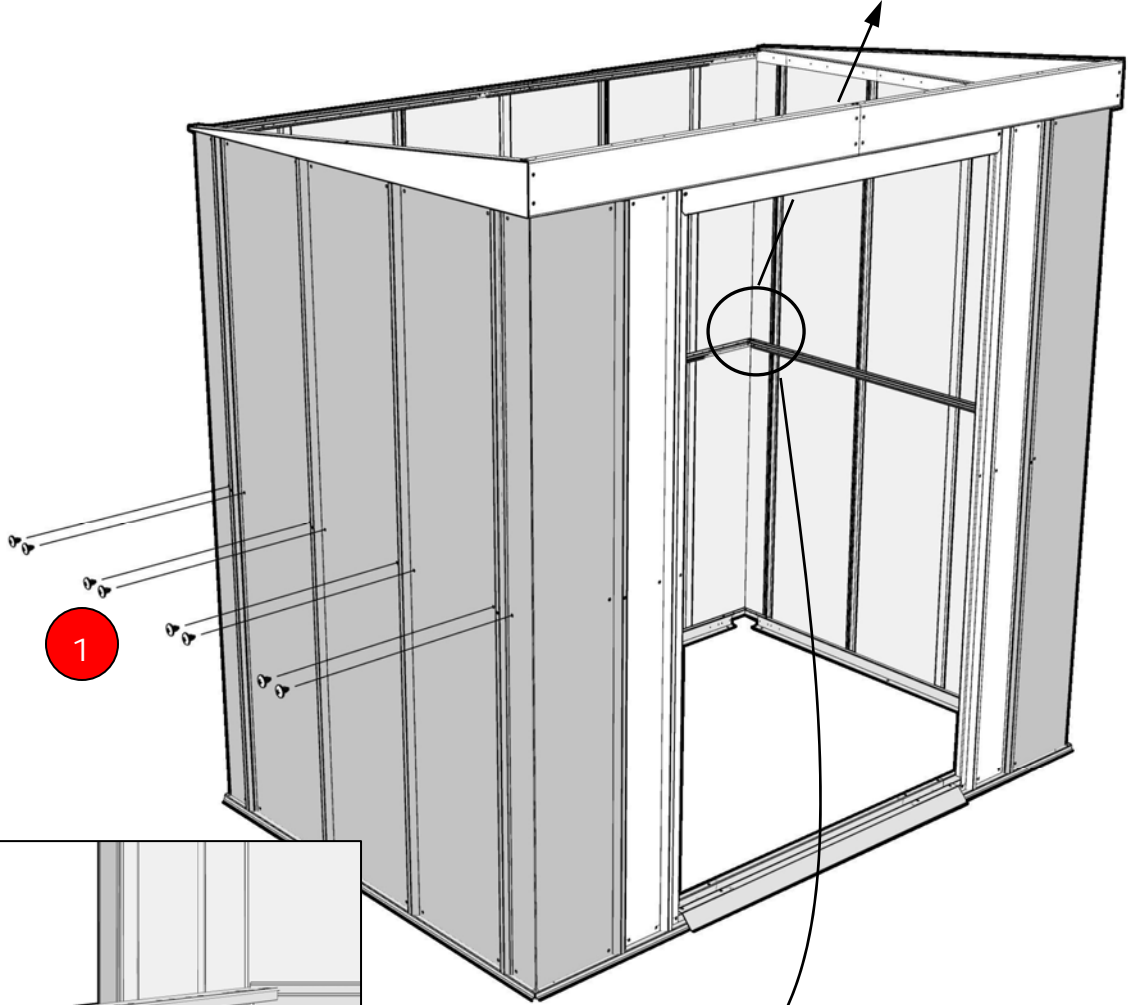
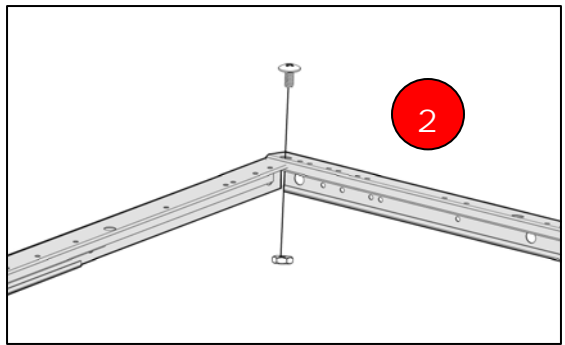

12 Outer Roof Panel – A419P (x2)
Assembled Roof Brace

IMPORTANT: Check to make sure the building is square and level before starting work on the roof sections.

Begin by fitting the two outer roof panels first. Position the roof panels so that the holes that are further in from the long edge align with the holes on the top lip of the gables. At this point, you will fit the roof brace the ends of which also align with the same center hole and is mounted underneath the top lip of the gables. Use self tapping screws with plastic washers.

NOTE: Holes down one long edge are further in than the other side. This side is the side which overhangs the side of the shed. Locate hole in center with the center hole in the top lip of the gable.

Center roof panel is exactly the same size but holes are at same distance from both edges. 4.5 cm (1.750")

OUTER ROOF PANEL

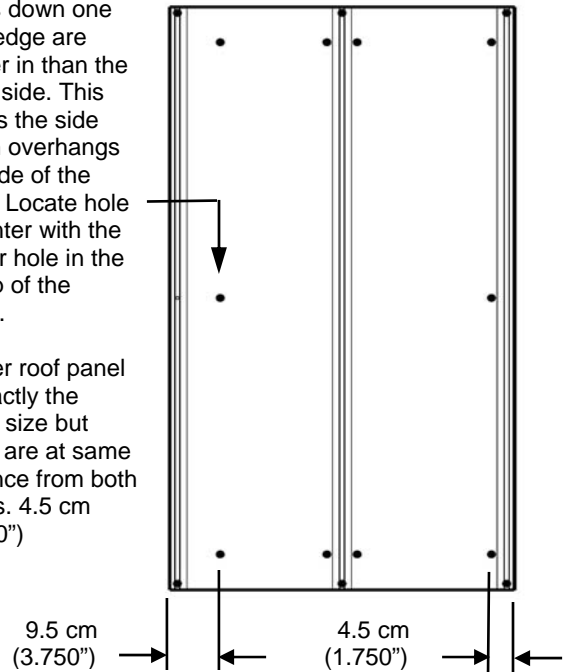

Use bolt and nut with plastic washer

NOTE: Use plastic washers on all fasteners.

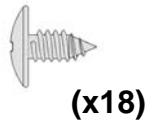
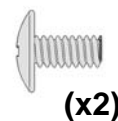
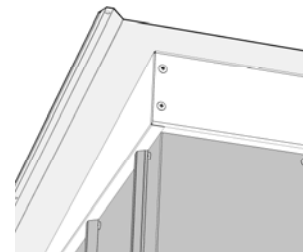
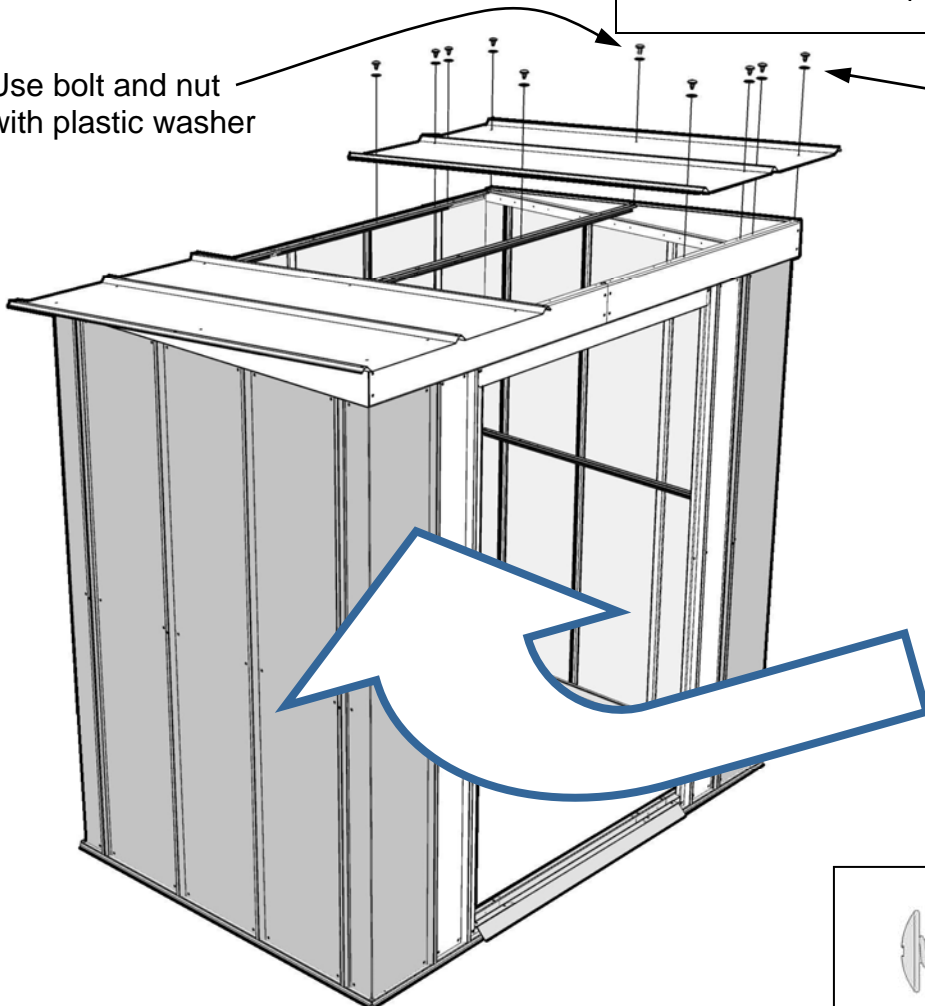

- 13** Center Roof Panel – B419P (x1)
 Roof Edge Trim – 641P (x4)
 Roof Edge Trim – 841P (x2)
 Roof Corner Cap – (x4)

1 Fill in the center area with the center roof panel. Secure all roof panels to the front fascia, gables, rear top rail and roof brace using self tapping screws with plastic washers.

2 Fit roof edge trim around the edges of the roof panels covering the corners with the plastic roof corner cap using bolts and nuts with plastic washers. Pieces are overlapped on the front and rear.

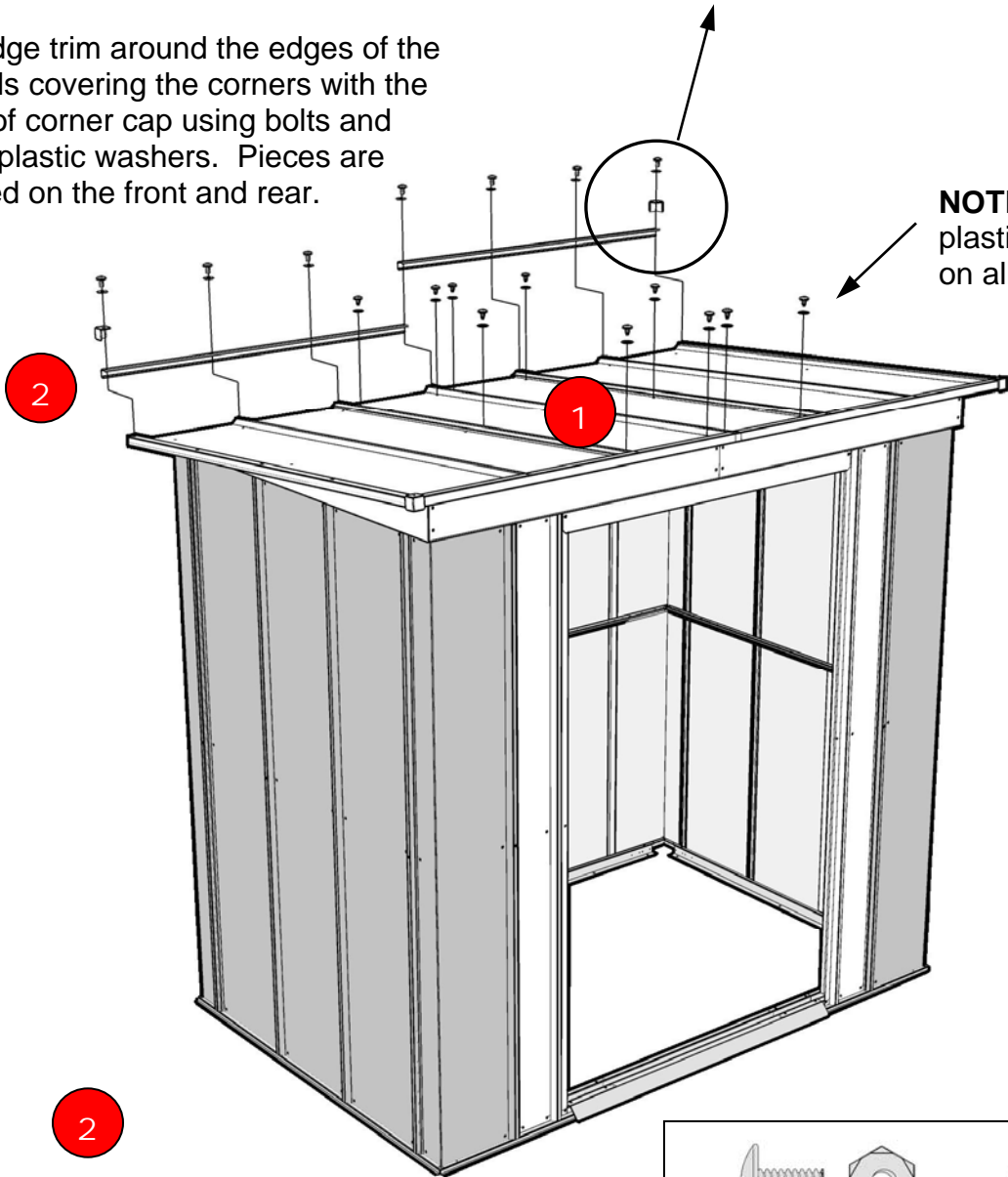
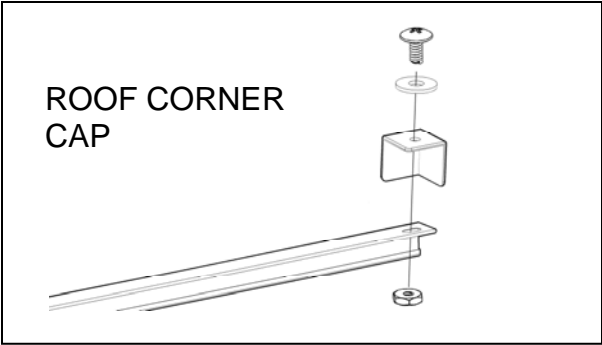

2

HINT: Fit all bolts and nuts loosely until all are inserted, and then tighten.

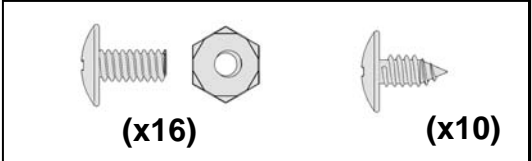

14 Anchor Building

IMPORTANT: Your building must be firmly anchored to a solid foundation to prevent damage caused in stormy conditions.

1 Center the building on the solid foundation. Check the base frame for squareness by measuring diagonal corners.

2 Secure the building to the solid foundation.

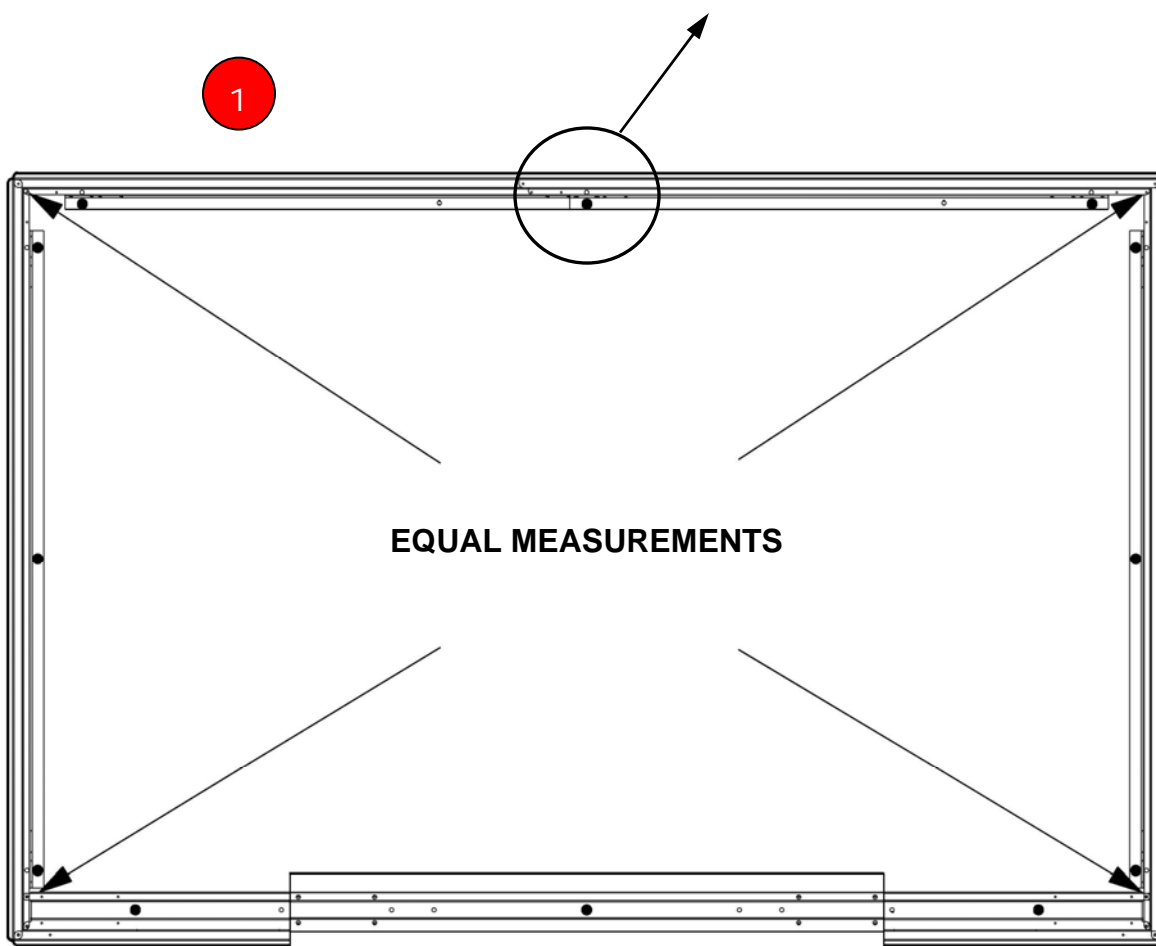
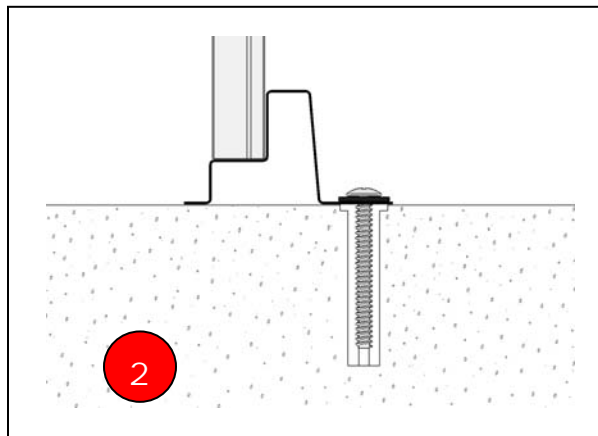

- 15** Door Panel – 622H__ (x2)
 Door Strengthener – DIS01 (x4)
 Adhesive Pad – (x4)
 Top & Bottom Door Brace – 632 (x4)
 Door Spacer – (x2)
 Door Handle – (x2)

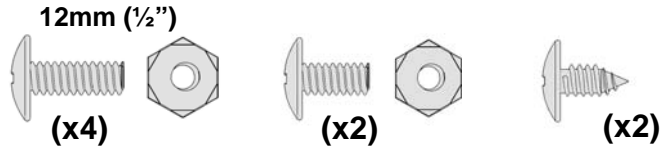

NOTE: Use plastic washers on all fasteners.

- 1 Position a door strengthener on the inside return lip of the door located by the door handle fixing holes.
- 2 Apply two adhesive pads to the surface of the door strengthener that will contact the door panel. Position this door strengthener on the opposite inside surface of the door.
- 3 Fasten bottom door brace to the door panel at the bottom using bolt and nut in holes located directly below the door handle holes. Fasten bottom door spacer at opposite end with self tapping screw. The door panel and end of door strengtheners fit into the door braces.
- 4 Fit door handle using 12mm (1/2") bolts and nuts.
- 5 Fit top door brace in the same way as the bottom door brace. Repeat for left door panel.

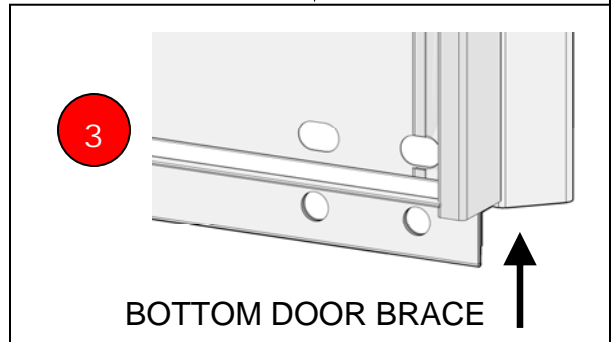
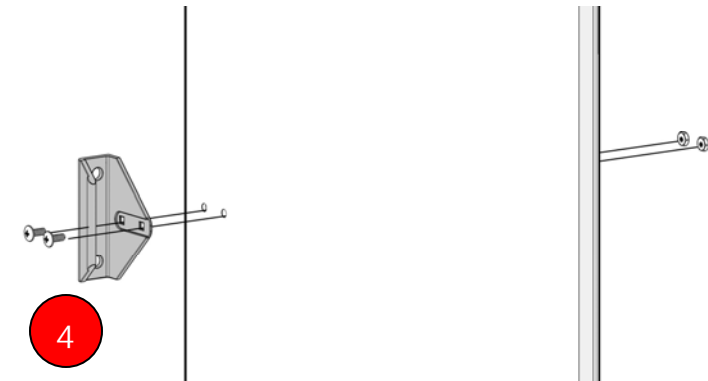
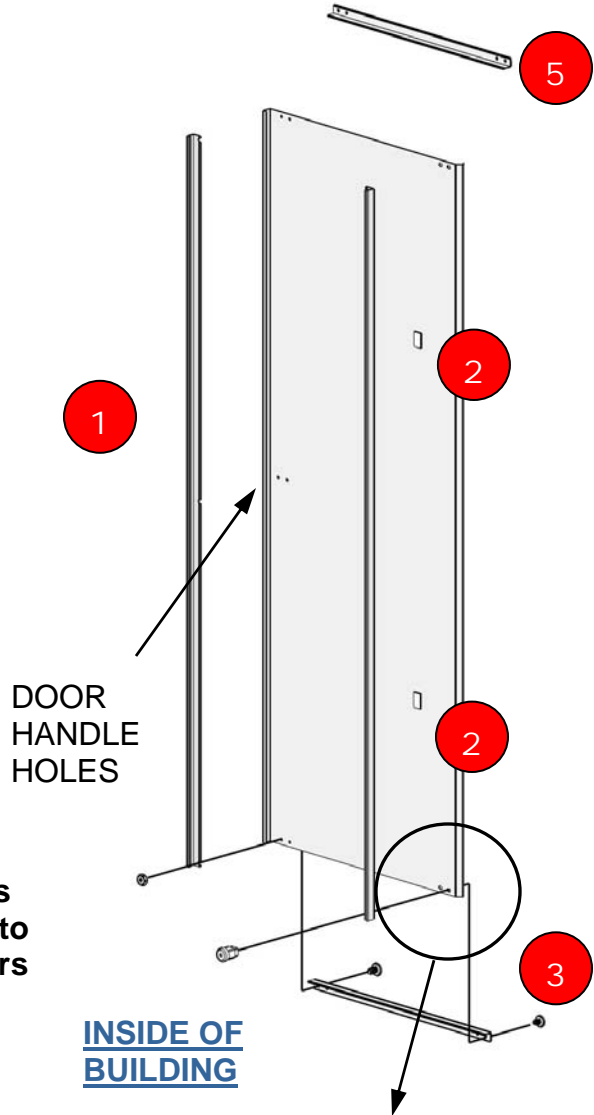

16

Assembled Doors

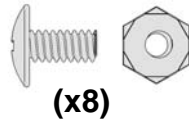

(x8)

1

From inside the building, insert the doors in the front base rail assembly, holding the door at an angle towards the inside.

2

Bring the doors up into a vertical position and secure to door glides with bolts and nuts.

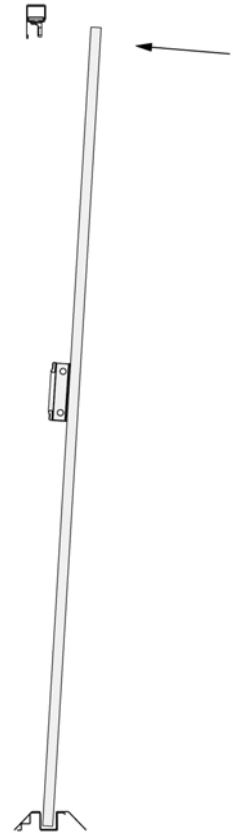
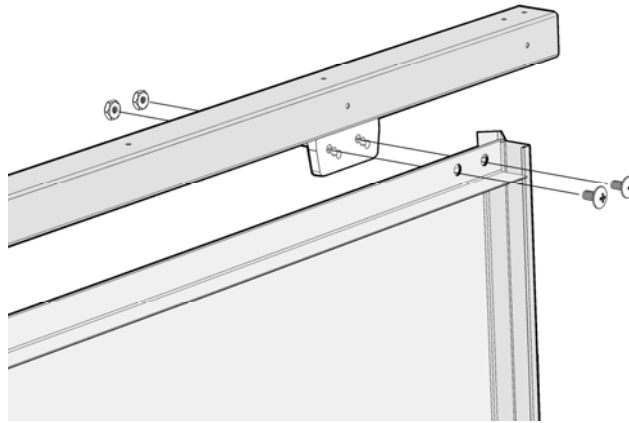

NOTE: The door glides have three hole positions that allow for door adjustment.

CARE and MAINTENANCE

Finish: For long lasting finish, periodically clean and wax the exterior surface. Touch up scratches as soon as you notice them on your building. Immediately clean the area with emery paper; wash it and apply touch paint per manufacturer's recommendation.

Roof: Keep roof clean of leaves and snow with long handled, soft bristled broom. Heavy amounts of snow on the roof can damage the building making it unsafe to enter.

Doors: Keep doors closed to prevent wind damage.

Fasteners: Regularly check your building for loose screws, bolts and nuts. Retighten them as necessary.

Moisture: With changing temperatures, condensation can accumulate inside the building.

Other Tips: A non-corrosive caulking is helpful to seal the building.

Do not store swimming pool chemicals in your building. Combustibles and corrosives must be stored in airtight containers.

REPLACEMENT PARTS OR ANY QUESTIONS REGARDING YOUR BUILDING SHOULD BE REFERRED DIRECTLY TO CUSTOMER SERVICE. DO NOT CONTACT YOUR DEALER, THEY ARE NOT EQUIPPED TO SERVICE YOUR REQUESTS AS PROMPTLY AS THE CUSTOMER SERVICE DEPARTMENT (1-800-851-1085).

PARTS REPLACEMENT ORDER FORM

<p>** MODEL NO. _____ **</p> <table border="1" style="width: 100%; border-collapse: collapse; margin-top: 10px;"> <thead> <tr> <th style="width: 33%;">PART NO.</th> <th style="width: 17%;">QTY.</th> <th style="width: 50%;">COLOR</th> </tr> </thead> <tbody> <tr><td> </td><td> </td><td> </td></tr> <tr><td> </td><td> </td><td> </td></tr> <tr><td> </td><td> </td><td> </td></tr> <tr><td> </td><td> </td><td> </td></tr> <tr><td> </td><td> </td><td> </td></tr> <tr><td> </td><td> </td><td> </td></tr> </tbody> </table> <p style="text-align: center; margin-top: 10px;">FOR PARTS REPLACEMENT PLEASE CONTACT CUSTOMER SERVICE DEPARTMENT. TELEPHONE NO. (1-800-851-1085)</p>	PART NO.	QTY.	COLOR																			<p>NAME: _____</p> <p>ADDRESS: _____</p> <p>CITY: _____ PROVINCE/STATE: _____</p> <p>POSTAL CODE/ZIP: _____ TELEPHONE: _____</p> <p>PURCHASED FROM: _____</p> <p>STORE ADDRESS: _____</p> <p>DATE PURCHASED: _____</p>
PART NO.	QTY.	COLOR																				

**or Mail To: 3069 Wolfedale Road
Mississauga, Ontario L5C 1V9**